

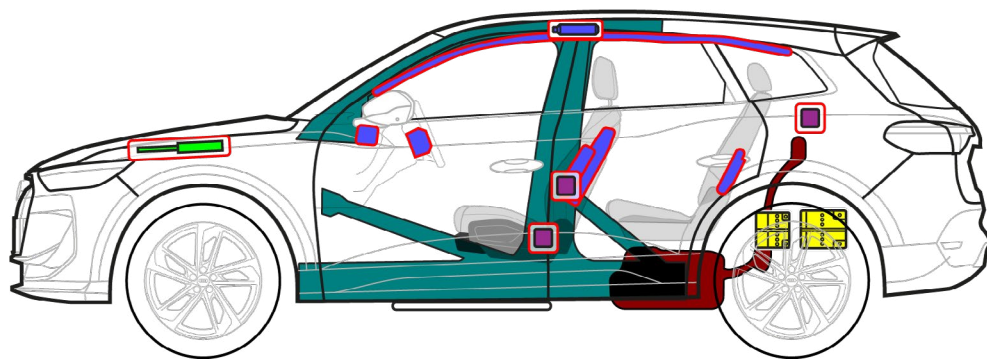

Audi Q5/SQ5

SUV, fra 2025

5-dørs model, med fem sæder

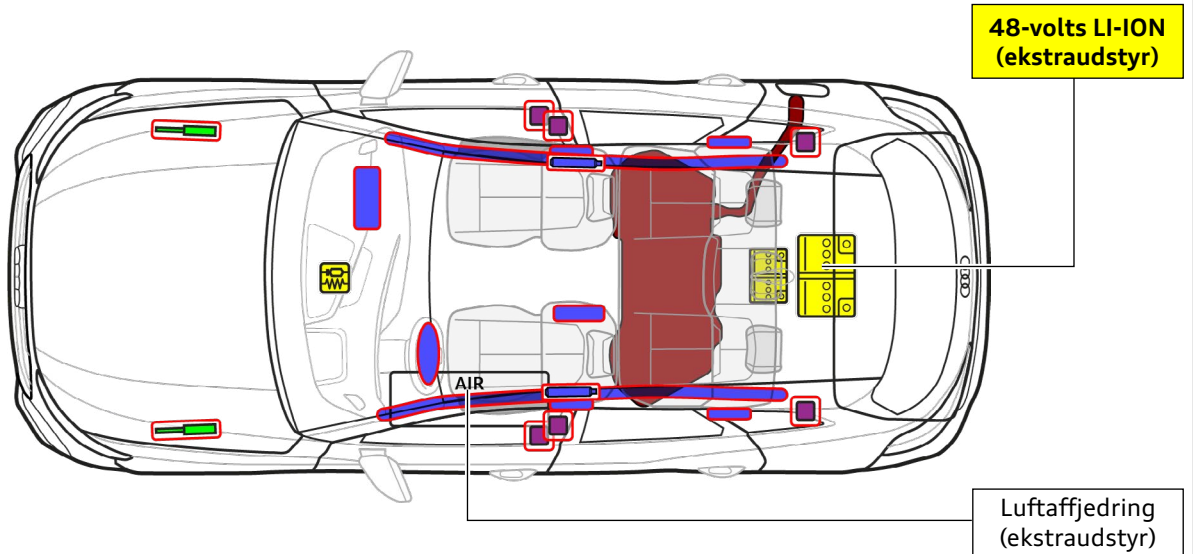

| | | | | | | | | | |
|--|------------------|--|--------------|--|-----------------|--|---------------------------------------|--|-------------------------------------|
| | Airbag | | Gasgenerator | | Selestrammer | | SRS-styreenhed | | Gastrykffjeder/ forspændt fjeder |
| | Højstyrkeområder | | Lufttank | | Lavvoltsbatteri | | Brændstoftank, benzin eller diesel | | |



Audi Q5/SQ5

SUV, fra 2025

5-dørs model, med fem sæder

1. Identifikation / genkendelse

Modelbetegnelse på B-stolpen



Modelbetegnelse på bagenden (kan fravælges)

2. Immobilisering / Stabilisering / Løft

Immobilisering af bil

- 1) Aktiver parkeringsbremsen.
- 2) Sikr bilen mod at rulle.



Løftepunkter

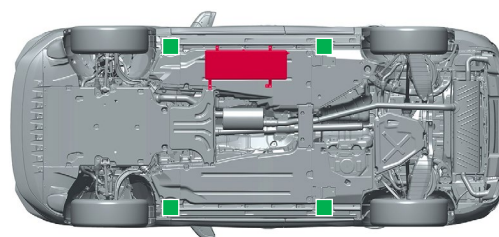

- Egnede løftepunkter
- Tryklufttank (ekstraudstyr)

3. Deaktivering af særlige farer / sikkerhedsforskrifter

Afbrydelse af tænding



Tryk på "Start-Engine-Stop"-knappen i midterkonsollen uden at træde på bremsepedalen.

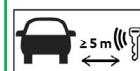

Hold så vidt muligt nøglen med fjernbetjening, nøglekortet og/eller smartphoneappen mere end 5 m væk fra bilen.

1) Afbrydelse af 12-volts-batteri i bagagerummet

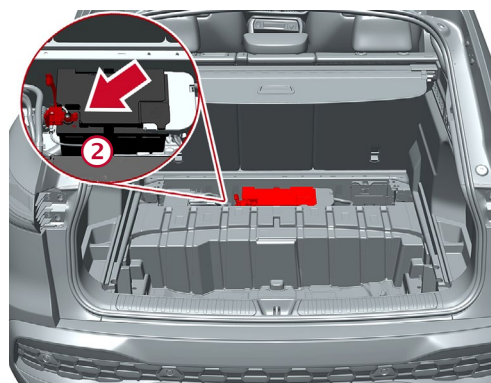
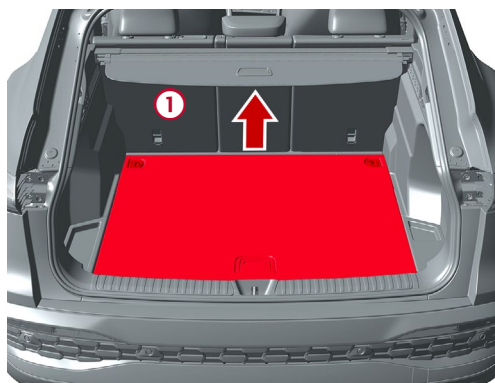
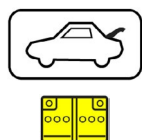

Fjern bundpladen:

- 1) For at gøre dette skal du løsne fastgørelsesøjernes samlingspunkter eller vippe bundpladen op med egnet værktøj.

- 2) Lokaliser 12-volts-batteriet, og afbryd minuspolen.



Audi Q5/SQ5

SUV, fra 2025

5-dørs model, med fem sæder

2) Afbrydelse af 48-volts-batteri (ekstraudstyr) i bagagerummet

Ved ulykker med airbagudløsning deaktiveres 48-volts-ledningsnettets automatisk efter registrering af airbagudløsningen.

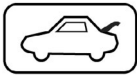

Derudover deaktiveres 48-volts-ledningsnettets efter ca. 10 sek. i følgende tilfælde:

- 1) Afbrydelse af tænding
- 2) Afbrydelse af 12-volts-batteri



I alle andre tilfælde kan 48-volts-ledningsnettets deaktiveres på følgende måde:

- 1) Fjern bundpladen (se Afbrydelse af 12-volts-batteri).

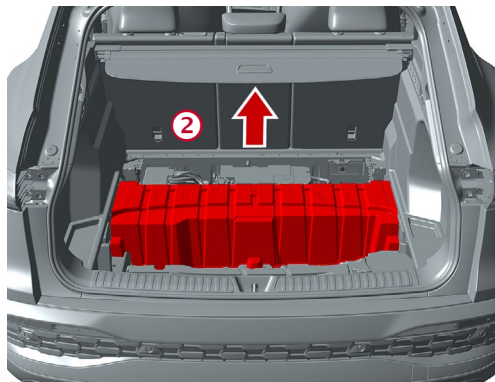

- 2) Fjern afdækningen til 48-volts-batteriet.

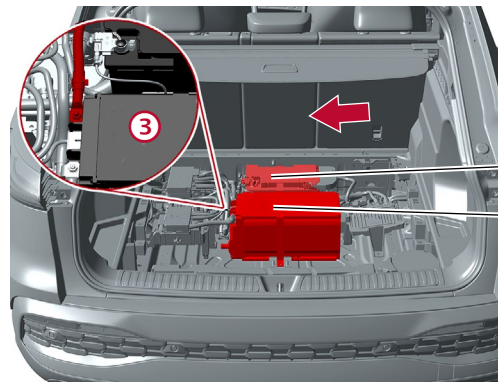

- 3) Lokaliser 48-volts-batteriet, og afbryd minuspolen.

12-volts-batteri

48-volts-batteri

4. Adgangsveje til tilskadekomne

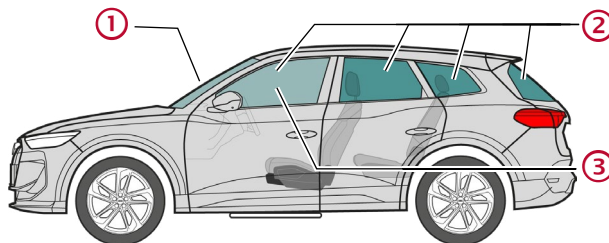

Glastyper:

- 1) Flerlagssikkerhedsglas
- 2) 1-lags-sikkerhedsglas
- 3) Flerlagssikkerhedsglas (ekstraudstyr)

5. Oplagret energi / væsker / gasser / faste stoffer

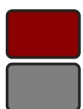

Benzin eller diesel
maks. 60 l



12 V



48 V
Litium-ion (ekstraudstyr)



Maks. 18 bar
(option)



Audi Q5/SQ5

SUV, fra 2025

5-dørs model, med fem sæder

6. I tilfælde af brand



Litium-ion-batterier kan selvantænde og efter brandslukningen antænde igen!
Brug passende beskyttelsesudstyr!



Utætheder i luftaffjedringsystemet (ekstraudstyr) kan medføre, at brandintensiteten øges.

7. I vand

Efter bjærgning skal man lade vandet løbe ud, og batteriet/batterierne skal afbrydes (se kapitel 3).
Brug passende beskyttelsesudstyr!

8. Bugsering / transport / opbevaring



Litium-ion-batterier kan selvantænde og efter brandslukningen antænde igen!
Brug passende beskyttelsesudstyr!



9. Vigtige ekstra oplysninger

Yderligere informationer i Audis redningshåndbog på www.audi.com/rescue

10. Piktograminformation

| | | | | | | | |
|-------------------------|--|--|---------------|-----------------------------|------------------------------|--------------------------------------|--------------------------|
| Brandfarlig | Ætsende, irriterende for huden | Farligt for menneskers sundhed | Miljøfare | Benzin brændstoftank | Brændstoftank, diesel | Brug vand til at slukke ilden | Fjern smart-nøgle |
| Lås bagagerum op | Generelt advarselsskilt | | | | | | |